



## VIT

Wall fixture IP44 VIT E27 15 Black White

### Technical features

Luminaire total power: 15W  
Structure material: Polycarbonate  
Structure finish: Black, White  
Diffuser material: Polycarbonate  
Diffuser finish: Opal  
Voltage / frequency: 100-240V/50-60Hz  
Warranty: 5 años  
Resistant to marine environments: No

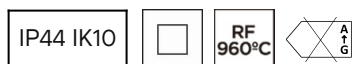

### Luminotechnic features

UGR crosswise: 26.3  
UGR lengthwise: 26.2

Lampholder	Quantity	Light source power (W)
E27	1	Max. power 15W

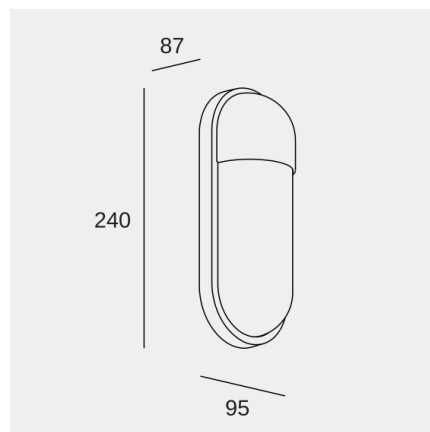

Image may not match reference. LedsC4 reserves the right to amend any of the product's components. The data related to flux, power and colour temperature may be subject to changes made by the manufacturer.



## VIT

Wall fixture IP44 VIT E27 15 Black White

## Logistics

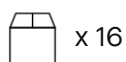

x 16

Net weight (kg): 0.35

Packaged weight (kg): 0.49

Packaging: 110mm x 105mm x 245mm

## Light application



Image may not match reference. LedsC4 reserves the right to amend any of the product's components. The data related to flux, power and colour temperature may be subject to changes made by the manufacturer.