

Modelo : AVNQ50GM2A5_AUUQ50GH5
Tipo : SPLIT UNITARIO TECHO
Modo de Operación : SÓLO FRIO
Tipo de Compresor : INVERTER
N° de Parte del Evaporador : AVNQ50GM2A5
N° de Parte : AUUQ50GH5
Unidad de Despacho : POR UNIDAD
Garantía de Fábrica : 12 MESES, ON-SITE
Empaque de Fabricación : EN CAJA
Modelo del Condensador : AUUQ50GH5
Modelo del Evaporador : AVNQ50GM2A5
SEER (W / W) / (BTU / hW) : 5.24 / 17.88
Capacidad de Enfriamiento Máx : 47,500 Btu/h



Unidad Interior



Unidad Exterior



RENDIMIENTO:

Capacidad Comercial (BTU/h)	48,000
Capacidad de Enfriamiento (Min ~ Max) (BTU/h)	13,800 ~ 47,500
Potencia de Entrada de Enfriamiento (kW)	4.53
Corriente de Funcionamiento (A)	19.9

Las prestaciones se basan en las siguientes condiciones:

Refrigeración : Temp. Ambiente Interior. 26,7°CDB / 19,4°CWB, temperatura ambiente exterior. 35°CDB / 24°CWB

Calefacción : Temp. Ambiente Interior. 21,1 ° CDB / 15,6 ° CWB, temperatura ambiente exterior. 8,3°CDB / 6,1°CWB

TECNOLOGÍA PRINCIPAL:

Tecnología de Compresor	INVERTER
EER (W/W)	2.85

ELECTRICIDAD:

Tensión de Funcionamiento / Frecuencia (V / Hz)	220 / 60
Número de Fases (Ø) x N°. Cables	Monofásico x 4C
MCA (A)	25.7
MFA (A)	30
Cable de Conexión Eléctrica (incluido Tierra) mm ² x N° - unidad interior	0.75 x 4C
Cable de alimentación (H07RN-F) mm ² x N°.- unidad exterior	4 x 3C

COMPRESOR:

Tipo	Hermetic Motor Compressor
Tipo de motor	BLDC
Salida del Motor (W x No.)	4000 x 1
Tipo de aceite	FW68D
Cantidad de carga de aceite (cc x No.)	1,300 x 1

REFRIGERANTE:

Tipo de refrigerante:	R410A
Cantidad de precarga (Kg):	2.2
Carga de refrigerante adicional (g /m)	40
Longitud de tubería sin carga (m)	7.5
Control	EEV

TUBERIA:

Líquido mm(pulg.)	Ø 9.52 (3/8)
Gas mm(pulg.)	Ø 15.88 (5/8)
Drenaje (drenaje natural) (O.D. / I.D.) mm	Ø 21.5 / 16

ENTRE INTERIOR Y EXTERIOR:

Longitud de tubería IDU - ODU (Nominal) (m)	7.5
Longitud de tubería IDU - ODU (Max / Min) (m)	50 / 7.5
Diferencia de altura máxima IDU - ODU (m)	30

CARACTERÍSTICAS ADICIONALES:

- * Incluye control remoto inalámbrico.
- * Incluye manual de usuario y manual de instalación.
- * Compare el retorno de su inversión con el aplicativo PayBack LG.

RANGO DE TEMPERATURA

Enfriamiento °C DB	Desde -10°C hasta 50°C
--------------------	------------------------

UNIDAD INTERIOR

Dimensiones netas (ancho x alto x profundidad) (mm)	1,600 x 235 x 690
Dimensiones de despacho (ancho x alto x profundidad) (mm)	1,715 x 320 x 772
Peso Neto / Bruto (Kg)	36.9 / 43.7
Nivel de Presión de Sonido dB(A)	- / 48.0 / 44.0 / 40.0
Color de carcasa	Morning Fog
Dispositivo de protección	Fusible

VENTILADOR (unidad interior)

Tipo	Cross Flow Fan
Rango de flujo de aire (Máx / H / M / L) (m ³ /min)	- / 30.0 / 25.0 / 20.0
Tipo de Motor	BLDC
Salida de Motor (W x No.)	125 x 1

INTERCAMBIADOR DE CALOR (unidad interior)

(Fila x Columna x Aletas x Pulgada) x No.	(3 x 18 x 18) x 1
Área frontal (m ²)	0.46

UNIDAD EXTERIOR

Dimensiones netas (ancho x alto x profundidad) (mm)	950 x 834 x 330
Dimensiones de despacho (ancho x alto x profundidad) (mm)	1,140 x 918 x 461
Peso Neto / Bruto (kg)	63 / 70
Nivel de Presión de Sonido dB(A)	57
Color de carcasa	Warm Gray
Material de carcasa	Fierro galvanizado pintado en horno de alta resistencia

VENTILADOR (unidad exterior)

Tipo	Axial
Rango de flujo de aire (m ³ /min x No.)	60 x 1
Tipo de Motor	BLDC
Salida de Motor (W x No.)	124 x 1

INTERCAMBIADOR DE CALOR (unidad exterior)

(Fila x Columna x Aletas x Pulgada) x No.	(2 x 38 x 14) x 1
---	-------------------

Nota:

MFA : Corriente para seleccionar el tamaño máximo permitido del interruptor termomagnético que desconectará correctamente la alimentación de la unidad condensadora bajo cualquier condición de corto circuito y de falla a tierra.

MCA : Corriente para seleccionar el tamaño mínimo del conductor necesario para garantizar que el cableado no entre en condición de sobrecalentamiento en todas las condiciones de funcionamiento durante la vida útil de la unidad condensadora.



AUUQ50GH5
AVNQ50GM2A5
SPLIT UNITARIO TECHO
48,000 BTU/h

Unidad exterior
Unidad interior
Capacidad Comercial



AVNQ50GM2A5

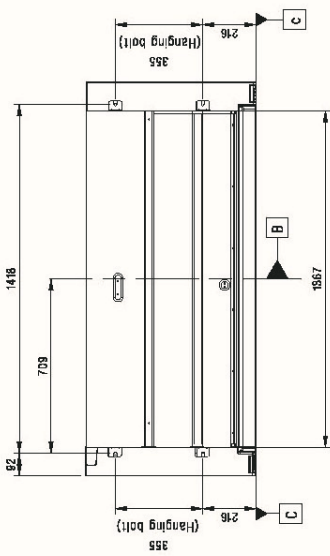
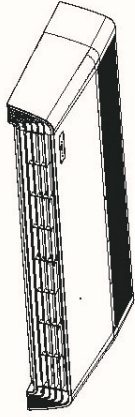

[Unit: mm]
Chassis code : VM2
DWG No. : TAZ35266401_Rev01

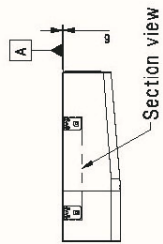
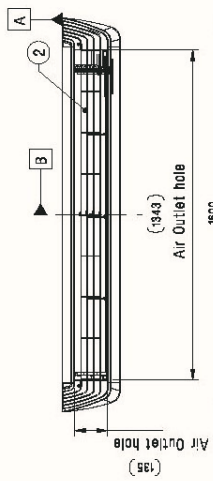
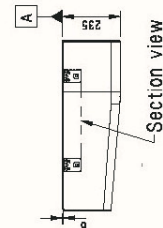
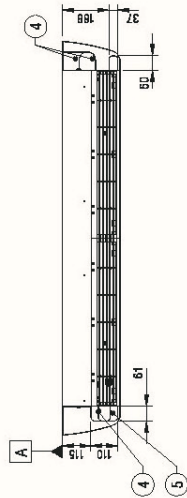

Note
1. Unit should be installed in compliance with the installation manual in the product box.
2. Unit should be grounded in accordance with the local regulations or applicable national codes.
3. All electrical components and materials to be supplied from the site must comply with the local regulations or international codes.

7	Liquid pipe connection	-	
6	Gas pipe connection	-	
5	Refrigerant pipe and cable routing hole	Knock-out type	
4	Drain hose routing hole	Knock-out type	
3	Remote Controller Signal Receiver	For wireless type	
2	Air outlet	-	
1	Air intake	-	
No.	Part Name		Description

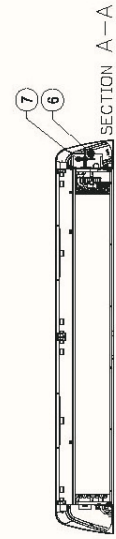

AUUQ50GH5
AVNQ50GM2A5
SPLIT UNITARIO TECHO
48,000 BTU/h

Unidad exterior
Unidad interior
Capacidad Comercial



AUUQ50GH5

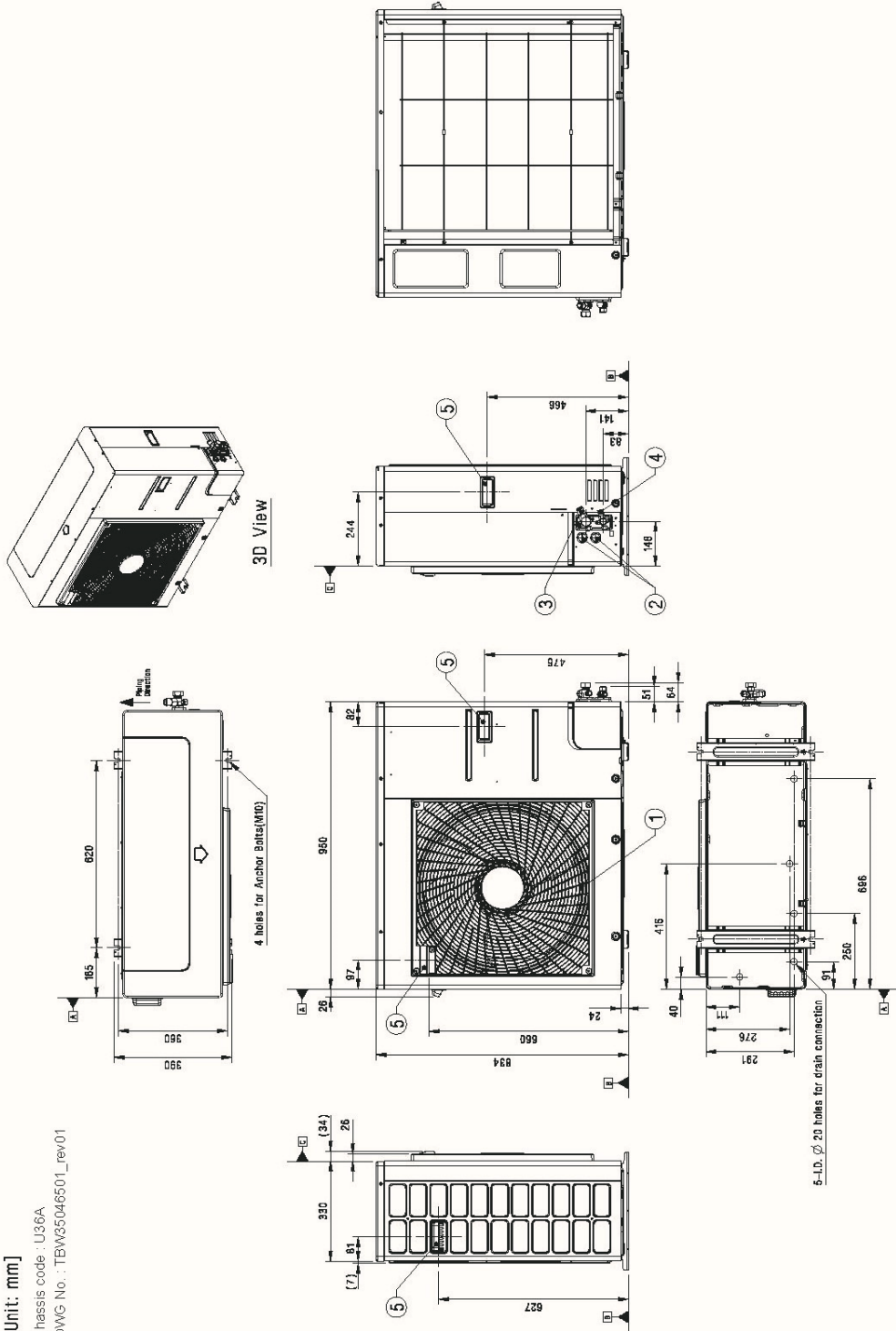

[Unit: mm]
 Chassis code : U36A
 DWG No. : TBW35046501_rev01

Symbols
 Piping Direction
 Datum line

Note
 1. Unit should be installed in compliance with the installation manual in the product box.
 2. Unit should be grounded in accordance with the local regulations or applicable national codes.
 3. All electrical components and materials to be supplied from the site must comply with the local regulations or international codes.
 4. Electric characteristics chapter should be considered for electrical work and design.
 Especially the power cable and circuit breaker should be selected in accordance with that.

No.	Part Name	Description
5	Handle	-
4	Liquid Pipe Connection	Flare joint
3	Gas Pipe Connection	Flare joint
2	Power and communication cable Hole	-
1	Air Outlet	-



CERTIFICATE



This is to certify that

LG Electronics Inc.

Air-Con. Division

84 Wanam-ro, Seongsan-gu
Changwon-si, Gyeongsangnam-do, 51554
Republic of Korea

with the organizational units/sites as listed in the annex

has implemented and maintains a **Quality Management System**.

Scope:

The design and manufacture of air conditioners, air purifiers, dehumidifiers, ventilators, furnaces and furnaces with air-conditioners.

Through an audit, documented in a report, it was verified that the management system fulfills the requirements of the following standard:

ISO 9001 : 2015

Certificate registration no.	20001747 QM15
Date of certification	2020-12-05
Valid until	2023-12-04



DQS Inc.

Brad McGulre
Managing Director

Accredited Body: DQS Inc., 1500 McConnor Parkway, Suite 400, Schaumburg, IL 60173 USA
Administrative Office: DQS Korea LLC., #302, ACE Techno Tower 10-cha,
196, Gasan digital 1-ro, Geumcheon-gu, Seoul, 08502, Republic of Korea



**Annex to certificate
Registration No. 20001747 QM15**

LG Electronics Inc.

Air-Con. Division

84 Wanam-ro, Seongsan-gu
Changwon-si, Gyeongsangnam-do, 51554
Republic of Korea

Location

Scope

509034
LG Electronics Inc.
LG Gasan R&D Campus

Product planning

51, Gasan digital 1-ro
Geumcheon-gu, Seoul, 08592
Republic of Korea

50350368
LG Electronics Inc.
LG Seoul Station Bldg.

Sales and marketing

Seoul Station Building, 98, Huam-ro
Jung-gu, Seoul, 04637
Republic of Korea